

### PRODUCT FEATURES:

#### Frame Rate Performance Examples:

- 12,500fps at 1024x1024 pixel resolution.
- 13,500fps at 1024x1000 pixel resolution.
- 22,500fps at 768x768 pixel resolution.
- 45,000fps at 512x512 pixel resolution.
- 60,000fps at 512x376 pixel resolution.
- 120,000fps at 256x280 pixel resolution.
- 300,000fps at 128x120 pixel resolution.
- 600,000fps at 128x24 pixel resolution.

#### Class Leading Light Sensitivity:

ISO 12232 Ssat (excluding IR response)

- ISO 25,000 monochrome
- ISO 10,000 color

#### Global Electronic Shutter

1ms to 1 $\mu$ s independent of frame rate (293ns shutter available subject to export control).

**Dual Channel Gigabit Ethernet Interface** provides fast image download.

#### Internal Recording Memory

8GB, 16GB, 32GB, 64GB.

#### Two Internal Memory Card Drives

Allowing high speed download of images to low cost removable SD memory cards.

**Flexible Frame Synchronisation** Frame rate may be synchronised to external non-stable frequencies.

**Sensor Size and Integrated Nikon G Type Lens Mount** allowing full compatibility with current DSLR lenses (DX and FX formats, G type Lens).

**Optional Sealed Camera Body 'RV' version** prevents the ingress of dust and particles in harsh test range environments.



### High performance camera system using the latest imaging technology to meet the requirements of the most demanding high-speed imaging applications

In order to meet the requirements of the most demanding high-speed imaging applications a balance of high frame rate, image resolution, dynamic range and light sensitivity is required. The FASTCAM SA-X2 high-speed camera system has been designed to provide a careful balance of all these sometimes conflicting requirements.

FASTCAM SA-X2 brings together unique CMOS image sensor technologies and digital imaging expertise to provide optimum imaging performance. The system offers recording rates up to 13,500fps at Megapixel image resolution with 12bit dynamic range and high image quality.

Light sensitivity is often the most critical performance criteria in high speed imaging. Without high light sensitivity, imaging at high frame rates with short exposure times is not possible. A camera system providing high light sensitivity allows objective lenses and lighting techniques to be optimized to visualise complex high-speed phenomena.

The FASTCAM SA-X2 system may be controlled over a high-speed Gigabit Ethernet network or via the optional keypad. The system is provided with an integrated capping shutter to facilitate automated image calibration and enhance ease of operation. The system is supplied with intuitive and feature rich Photron FASTCAM Viewer (PFV) software and Photron Device Control SDK (software development kit) allowing integration with user specific software. Alternatively the camera can be controlled as a device within a MATLAB or LabVIEW environment.

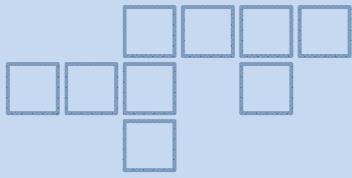

# FASTCAM SA-X2

HIGH PERFORMANCE HIGH-SPEED CAMERA SYSTEM

## Image Sensor Technical Data:

Sensor Type	Proprietary Design Advanced CMOS
Maximum Resolution (pixels)	1024 x 1024 pixels
Sensor Size / Diagonal	20.48 x 20.48mm / 28.96mm
Pixel Size (microns)	20µm x 20µm
Quantum Efficiency	49% at 630nm
Full Well Capacity	16,000e-
Fill Factor	58%
Dark Noise	29e-
Sensor Dynamic Range	54.8 dB
Color Matrix	Bayer CFA (single sensor)
ISO 12232 Ssat sensitivity	ISO 25,000 mono, ISO 10,000 color (mono sensor equivalent > ISO40,000 T including near IR response)
Shutter	Global Electronic Shutter 1ms to 1µs independent of frame rate. (Sub microsecond shutter providing a minimum exposure time of 293ns available subject to export control)

### Light Sensitivity:

Expressions of light sensitivity in high-speed cameras can be confusing as a variety of differing measurement techniques are used. Photron publishes light sensitivity figures for its products using the ISO 12232 Ssat standard.

FASTCAM SA-X2	ISO 12232 Ssat
Monochrome models	ISO 25,000
Color models	ISO 10,000

ISO 12232 values published by Photron for both monochrome and color cameras are measured excluding infra-red sensitivity as defined by the ISO standard. Monochrome sensors used in FASTCAM SA-X2 cameras are supplied without an IR filter, extending the camera spectral response beyond 900nm. When the sensitivity of the FASTCAM SA-X2 camera is measured to tungsten light including near IR response an equivalent value greater than ISO 40,000 T is obtained.

### Image Sensor:

The FASTCAM SA-X2 system uses an advanced CMOS image sensor that is unique to Photron. The pixel pitch of the sensor is 20 microns giving a sensor size at full resolution of 20.48 x 20.48 mm (diagonal 28.96mm).

Lenses designed for both FX (35mm full frame) and also DX (APS-C digital SLR) formats are compatible with the FASTCAM SA-X2 at full image resolution.

## Image Sensor Spectral Response:

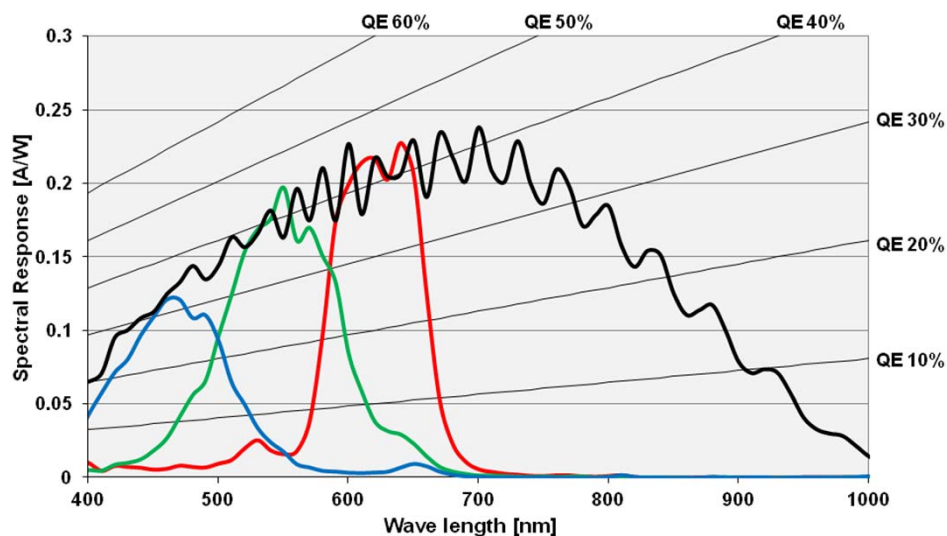

# FASTCAM SA-X2

HIGH PERFORMANCE HIGH-SPEED CAMERA SYSTEM

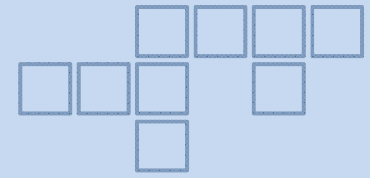

## Camera Performance Specifications:

Maximum Frame Rate (full sensor resolution)	12,500fps at 1024 x 1024 pixels
Maximum Frame Rate (reduced image resolution)	480,000fps at 128 x 48 pixels (1,000,000fps at 128 x 8 pixels resolution available subject to export control)
Shutter Time	Global electronic shutter 1ms to 1 $\mu$ s independent of frame rate. (293ns shutter available subject to export control)
Mechanical Calibration Shutter	Standard feature
Dynamic Range (ADC)	12-bit
Memory Capacity Options	8GB: 5,455 frames at full resolution 16GB: 10,916 frames at full resolution 32GB: 21,839 frames at full resolution 64GB: 43,684 frames at full resolution
Removable Memory Storage	2x SD/SDHC/SDXC memory Card drives provided. Compatible with UHS-I (SDR104) 
Region of Interest	Selectable in steps of 128 pixels (horizontal) x 8 pixels (vertical)
Trigger Inputs	Selectable +/- TTL 5V and switch closure
Trigger Delay	Programmable on selected input / output triggers: 100ns resolution
Trigger / Synchronization Outputs	For synchronisation of multiple cameras or external equipment +/- TTL 5V p-p
Trigger Modes	Start, End, Centre, Manual, Random, Random Reset, Image trigger, Time Lapse
Time Code Input	IRIG-B
Video Outputs	Live and playback via dual HD-SDI or RS-170 (NTSC/PAL) (zoom, pan, scroll control via optional LCD keypad)
Camera Control Interface	High Speed Dual Gigabit Ethernet and RS-422
Remote Control	Optional handheld control keypad
Image Data Display	Frame rate, Shutter speed, Trigger Mode, Date/Time, Status, Real time / IRIG Time, Frame count, Resolution
Saved Image Formats	BMP, TIFF, JPEG, PNG, RAW, RAWW, MRAW, AVI, WMV, FTIF, MOV. Images can be saved with or without image data and in 8-bit / 16-bit or bit depth of sensor where supported

## High-Speed Dual Gigabit Ethernet Interface:

FASTCAM SA-X2 camera system is equipped with a high-speed Dual Gigabit Ethernet interface to provide reliable network communication and fast download of image data to notebook PCs without the requirement for server based 10Gb Ethernet hardware.

Sample data download rates obtained using the camera in combination with current generation notebook PCs fitted with Core i7 (2.7GHz) processor, Solid State Drive and dual Gigabit Ethernet inputs allows 32GB of image data to be transferred from camera memory to storage on the PC in 2 minutes.

## Mechanical Calibration Shutter:

A mechanical shutter fitted as standard to the FASTCAM SA-X2 camera allows sensor black balance calibration to be carried out remotely from the system control software.

The FASTCAM SA-X2 camera has been designed for effective thermal management, ensuring high image stability even with used for extended periods in harsh operating environments.

## Nikon G type Compatible Lens Fitting:

The FASTCAM SA-X2 camera is equipped with an objective lens mount compatible with readily available Nikon G type lenses. Controls provided within the lens mount allow the control of lens aperture on lenses without external iris control.



An optional lens mount supporting Canon EF lenses is available for the FASTCAM SA-X2 providing remote control of lens aperture and iris through Photron PFV software.

**Photron**  
High-Speed Imaging Solutions

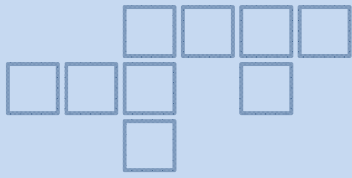

# FASTCAM SA-X2

HIGH PERFORMANCE HIGH-SPEED CAMERA SYSTEM



## Camera Operation Features:

Dual Slope Shutter (Extended Dynamic Range)	Selectable in 20 steps (0 to 95% in 5% increments) to prevent pixel over exposure without post processing
12-bit / 8-bit Recording Modes	User selectable high quality 12bit recording mode or 8bit mode compatible with industry standard file formats while increasing available recording durations
Memory Partitions	Up to 64 memory segments allow multiple events to be stored in camera memory before downloading, with automatic progression to the next available partition
Low Light Mode	Operation at minimum frame rate with separately adjustable shutter time to allow easy camera set-up and focus in ambient lighting
User Switches	Four user defined camera function controls provided on the camera rear panel
IRIG Phase Lock	Enables multiple cameras to be synchronised together with other instrumentation equipment to a master external time source
Internal Delay Generator	Allows programmable delays to be set on input and output triggers, 100ns resolution
Event Markers	Up to ten user entered event markers to define specific events within the recorded image sequence
Download While Recording	FASTCAM SA-X2 supports Partition Recording Mode allowing image data captured in one memory partition to be downloaded while at the same time recording into another partition
Automatic Download	The system can be set to automatically download image data to the control PC, and when download is complete re-arm in readiness for the next trigger with automatically incremented file names
Software Binning	Virtual pixel binning (2x2, 4x4 etc) allows increased light sensitivity with reduced image resolution without changing camera field of view

## Removable Memory Storage:

Two UHS-I (SDR104) compatible SD memory card drives allow image data captured to camera memory to be quickly transferred to low cost storage media, allowing a new image sequence to be recorded to camera memory. Control of download operation using on-camera user switches or via the optional Remote Control Keypad allows full camera operation and data storage without the requirement for connection to a computer



## Remote Control LCD Keypad:

An optional hand-held remote control keypad is available for the FASTCAM SA-X2 to enhance field operation. The keypad provides an operator with local control of all primary camera functions to simplify camera set-up without the need for a computer.

# FASTCAM SA-X2

HIGH PERFORMANCE HIGH-SPEED CAMERA SYSTEM

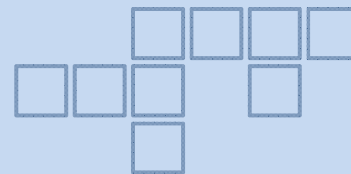

## Frame Rate / Image Resolution:

Frame Rate (FPS)	Image Resolution (Pixels)	
	Horizontal	Vertical
1,000 to 12,500 fps	1024	1024
13,500 fps	1024	1000
15,000 fps	1024	896
20,000 fps	1024	672
30,000 fps	896	496
40,000 fps	768	416
50,000 fps	640	384
60,000 fps	512	376
81,000 fps	512	256
100,000 fps	384	264
150,000 fps	256	216
200,000 fps	256	152
324,000 fps	256	72
480,000 fps	128	48
900,000 fps* <sup>1</sup>	128	8
1,000,000 fps* <sup>1,*2</sup>	128	8

(\*<sup>1</sup> Model 1000K Frame rate settings exceeding 480,000 fps subject to export control)

(\*<sup>2</sup> Frequency settings above 900,000 fps require external synchronization)

## Recordable Image Count (12bit recoding mode \*)

Image Resolution (pixels)	8GB Memory (frames)	16GB Memory (frames)	32GB Memory (frames)	64GB Memory (frames)
1024 x 1024	5,455	10,916	21,839	43,684
1024 x 1000	5,586	11,178	22,363	44,733
1024 x 896	6,234	12,476	24,959	49,925
1024 x 672	8,313	16,635	33,280	66,568
896 x 496	12,874	25,760	51,531	103,074
768 x 416	17,909	35,833	71,682	143,379
640 x 384	23,282	46,584	93,187	186,394
512 x 376	29,723	59,469	118,963	237,950
512 x 256	43,656	87,347	174,728	349,491
384 x 264	56,445	112,934	225,912	451,868
256 x 216	103,485	207,048	414,174	828,426
256 x 152	147,058	294,227	588,564	1,177,238
256 x 72	310,459	621,148	1,242,527	2,485,283
128 x 48	931,382	1,863,450	3,727,585	7,455,855
128 x 8	5,588,307	11,180,712	22,365,523	44,735,144

(\* Approximate recordable image count with 8bit recording mode can be calculated by multiplying the figures above by 1.5)

## Variable Region of Interest mode:

Region of Interest (ROI) or sub-windowing allows a specific user-defined portion of the sensor to be used to capture images. By using just a selected portion of the image area, the frame rate at which images are recorded can be increased. FASTCAM SA-X2 allows size of the ROI to be set in 64 pixel increments and vertical size to be set in 8 pixel increments.

## Square Image Sensor Format:

Unlike broadcast and media applications where image formats such as 16:9 have now become standard, in scientific and industrial imaging applications an image sensor with a 1:1 image format is generally accepted to be advantageous. To capture the maximum useful image data in applications (including microscopy, detonics, combustion imaging and many others), a 1:1 sensor format provides greater flexibility than 'letterbox' image formats. The FASTCAM SA-X2 image sensor allows the user to choose either square or rectangular image formats in order to obtain the maximum subject information.

## External Frame Synchronisation:

The FASTCAM SA-X2 camera can be fully synchronised with an external event to allow the timing of when each individual image is captured to be precisely referenced. The camera can be accurately synchronised to unstable frequencies allowing complex events such as combustion in rapidly accelerating or decelerating engine to be recorded and studied.

## Record During Save Operation:

FASTCAM SA-X2 recording memory can be divided into multiple active sections. The user can record an on-going event in one memory partition while at the same time downloading a previously recorded image sequence this can be used improve workflow and optimise camera operation.

**Photron**  
High-Speed Imaging Solutions

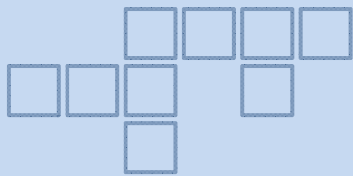

# FASTCAM SA-X2

HIGH PERFORMANCE HIGH-SPEED CAMERA SYSTEM

## Photron FASTCAM Viewer:

Photron software provides a robust and reliable interface for control of the FASTCAM SA-X2 camera. Clear on-screen controls provide intuitive operation of FASTCAM SA-X2 camera functions. Advanced operation menus provide access to features for enhanced camera operation, image replay and export.

Included are tools allowing image calibration and simple measurement of angle and distances from image data.

## National Instruments DAQ support:

A software plug-in is available for the FASTCAM SA-X2 to support National Instruments USB-6361 / USB-6363 BNC DAQ modules. Optimized for superior accuracy and fast sampling rates, the system allows up to 32 channels (single ended) and 16 channels (differential) analogue data at sampling rates up to 2MS/s to be captured alongside high speed image data from the FASTCAM camera. This option allows a graphic display of DAQ data to be replayed in PFV software precisely synchronized and automatically linked with high speed images. 'Level Detection Triggering' allows the system to monitor data acquisition signals from an event and automatically trigger the high speed camera to start or stop recording images when levels exceed user pre-set reference values, allowing unpredictable and intermittent events to be reliably captured.

## Motion Analysis:

PFV software allows image sequences to be exported directly to optional PFA Motion Analysis software. This entry level Motion Analysis software with an on screen 'step by step guide' function launches automatically from Photron FASTCAM Viewer software, and provides automated tracking of up to 5 points using a correlation tracking algorithm for the analysis of motion within an image sequence. Measurements of displacement, velocity and acceleration can be displayed and exported as comma separated values (csv files) to MS Excel etc.

**Photron**  
High-Speed Imaging Solutions

## FASTCAM SA-X2 Operation Software Features:

Image Calibration	2D image calibration allows the measurement of distances and angle from the image. A calibration grid overlay can be superimposed on the image
Image Overlay	A stored reference image may be overlaid on the live image to allow accurate camera positioning to achieve the same view as a previous test
Import of Multiple Image Sequences	Multiple image sequences can be loaded and simultaneously replayed. Timing of image sequences can be adjusted to create a common time reference. Time based synchronisation allows images captured at different frame rates to be synchronised
High Dynamic Range mode	Making use of the full sensor dynamic range, HDR mode allows enhanced detail in both light and dark areas of an image to be displayed simultaneously
Motion Detector	In order to highlight subtle changes in an image Motion Detector allows a reference image to be subtracted from a recorded sequence. Details including propagation of shock waves and surface changes during impact can be visualised using this feature
Line Profile	A line profile representing grey levels along a line drawn across any region of the image is displayed. In live mode Line Profile can be used to ensure optimum image focus is achieved.
Histogram	A histogram displaying grey levels within a user defined image area is displayed. In live mode the Histogram can be used to ensure that optimum exposure levels are set for the scene being recorded.

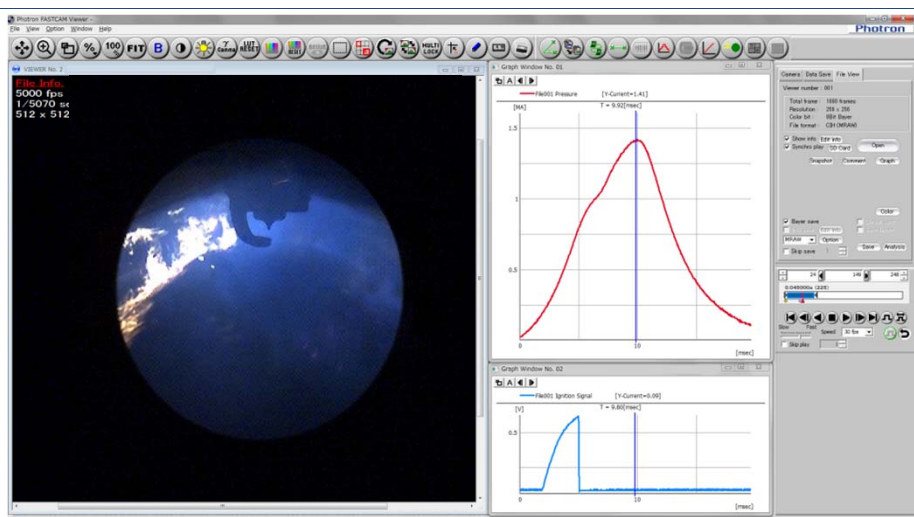

Photron FASTCAM Viewer image display together with synchronised data acquisition measurement

# FASTCAM SA-X2

HIGH PERFORMANCE HIGH-SPEED CAMERA SYSTEM

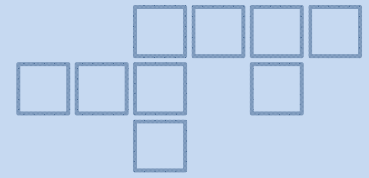

## Mechanical and Environmental Specifications:

### Mechanical

**Lens Mount** F mount (G-type lens compatible) and C mount provided. Optional lens mounts available include Canon EF

**Camera Mountings** 1x ¼ - 20 UNC, 1x 3/8 – 16 UNC, 6x M5 (base and two sides)

**External Dimensions** (excluding protrusions)

**Camera Body** 177.7 (H) x 160 (W) x 350 (D) mm  
7.0" (H) x 6.3" (W) x 13.7" (D)

### Weight

**Camera Body** 9.9kg / 21.82 lbs

### Environmental

**Operating Temperature** 0 ~ 40 deg. C (standard model)  
0 ~ 45 deg. C (RV model)

**Storage Temperature** -20 ~ 60 deg C.

**Humidity** 85% or less (non condensing)

**Cooling** Standard model - Internal fan cooling  
RV model - External fan with high performance thermal design

### Power

**AC Power** (with supplied adapter) 100 ~ 240V, 50 ~ 60 Hz, 210W

**DC Power** 18 ~ 36V, 210VA

## FASTCAM SA-X2 RV (Range Version):

An optional 'sealed case' version of the FASTCAM SA-X2 camera is available, designed specifically for use in high temperature conditions and locations where high levels of dust or particle contaminants may be present.



The FASTCAM SA-X2 RV camera utilises thermal management structures within the camera body to ensure that during operation heat can be dissipated via a high performance heat sink on the top of the camera body. An externally mounted fan ensures optimum air flow and prevents dust and corrosive particles from being ingested within the camera body.

The RV model of the FASTCAM SA-X2 camera has been extensively tested to ensure operation for extended periods in ambient temperatures up to 45 degrees C.

### Rugged Design:

Both the standard FASTCAM SA-X2 system and the RV model have been designed for operation in harsh environments.

Usage of the system in high shock conditions has been confirmed by testing the system at 30G, 10ms, 6 axis during operation.

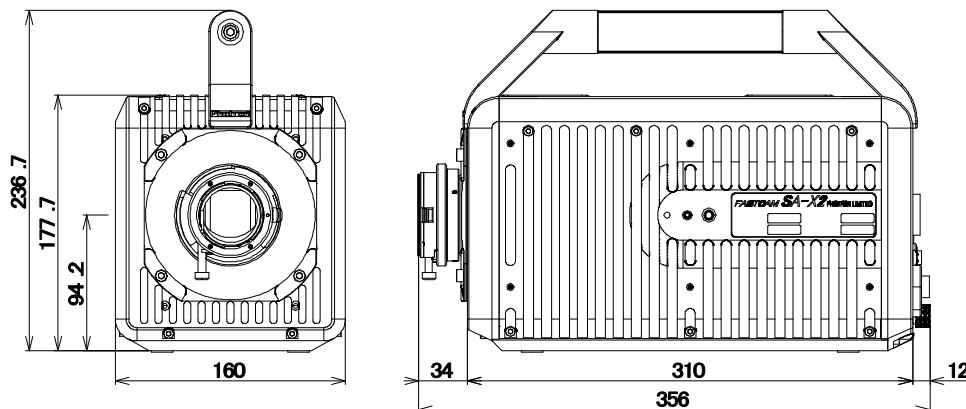

All dimension are given in millimeter

**Photron**  
High-Speed Imaging Solutions

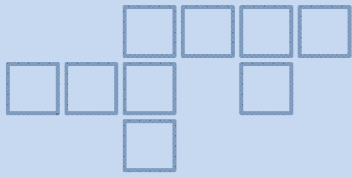

# FASTCAM SA-X2

HIGH PERFORMANCE HIGH-SPEED CAMERA SYSTEM

## Credibility and reputation through technological achievement:

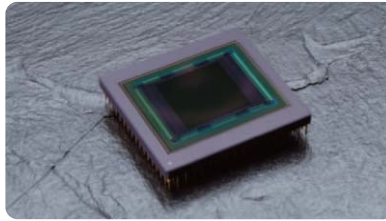

Developments in advanced imaging technologies pioneered by Photron over the past 20 years are now being utilized in high-speed camera systems designed for a range of scientific and industrial development applications. Photron has invested in the development of unique

advanced CMOS image sensors, the core technology of high speed photography. Innovations in this area have led to a rapid increase in camera performance allowing high-speed imaging to be applied to important new subject areas.

## The highest quality design, manufacturing and support:

As an ISO9001:2008 certified manufacturer, Photron manufactures its full range of imaging systems at its own facility located in Yonezawa City Yamagata Prefecture, Japan.

International technical support centres located in the USA, Europe and China staffed by factory trained engineers and holding a full range of support equipment ensure fast and professional local support for Photron camera users around the world.



## FASTCAM, the leading name worldwide in high speed imaging:



Used in internationally renowned research facilities more than 30 countries worldwide, Photron FASTCAM high speed cameras are trusted to provide high quality results in the most challenging applications and environments. Photron continues to utilise the latest technological innovations to

further advance product performance in order to meet the most demanding requirements from users around the world.

## Specialist high-speed imaging applications knowledge:

For more than 30 years Photon has focussed on the design and application of high-speed imaging products. Photron's specialist applications engineers have a wealth of knowledge and experience in demanding imaging requirements and are able to advise both new and experienced users on High-speed imaging solutions and imaging techniques to achieve the optimum results.



## Contacts:

### PHOTRON LIMITED

Kanda Jinbo-cho 1-105  
Chiyoda-Ku, Tokyo 101-0051  
Japan

Tel: +81 (0) 3 3518 6271

Fax: +81 (0) 3 3518 6279

Email: [image@photron.co.jp](mailto:image@photron.co.jp)

[www.photron.co.jp](http://www.photron.co.jp)

### PHOTRON (SHANGHAI) LIMITED

Room 20C, ZhaoFeng World Trade Building  
NO.369, JiangSu Road, ChangNing District  
Shanghai 200050  
China

Tel: +86 (0)21-5268-3700

Fax: +86 (0)21-5268-3702

Email: [info@photron.cn.com](mailto:info@photron.cn.com)

[www.photron.cn.com](http://www.photron.cn.com)

### PHOTRON USA, INC.

9520 Padgett Street, Suite 110  
San Diego, CA 92126-4446  
USA

Tel: 858 684 3555 or 800 585 2129

Fax: 858 684 3558

Email: [image@photron.com](mailto:image@photron.com)

[www.photron.com](http://www.photron.com)

### PHOTRON (EUROPE) LIMITED

The Barn, Bottom Road  
West Wycombe  
Buckinghamshire, HP14 4BS  
United Kingdom

Tel: +44 (0) 1494 481011

Fax: +44 (0) 1494 487011

Email: [image@photron.com](mailto:image@photron.com)

[www.photron.com](http://www.photron.com)

# Photron

High-Speed Imaging Solutions